

**STERLING**  
**ELECTRIC, INC.**

# **2000HG<sup>®</sup>**

---

## **NEW STYLE HELICAL GEAR RATIO MULTIPLIER**

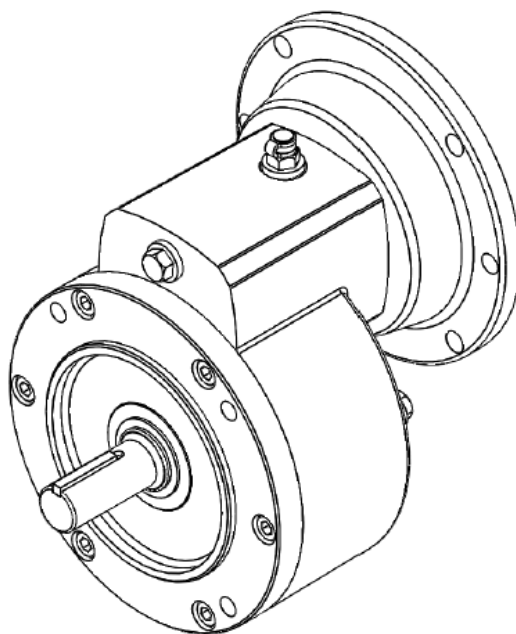

### **INSTALLATION AND MAINTENANCE MANUAL**

May 4, 2017

Indianapolis, Indiana (800) 866-7973

e-mail: [sales@sterlingelectric.com](mailto:sales@sterlingelectric.com)  
[www.sterlingelectric.com](http://www.sterlingelectric.com)

## **2000HG NEW STYLE HELICAL GEAR RATIO MULTIPLIER INSTRUCTION MANUAL**

### **SELECTION INFORMATION**

Read ALL instructions prior to operating unit. Improper maintenance or operation may cause injury to personnel or reducer failure.

Written authorization from Sterling Electric is required to operate or use this unit in man lift or people moving devices.

Check to make certain application does not exceed the allowable load capacities published in the current catalog.

Buyer shall be solely responsible for determining the adequacy of the product for any and all uses to which buyer shall apply the product. The application by buyer shall not be subject to any implied warranty of fitness for a particular purpose. Information contained in this manual is considered correct at the time of publication and is subject to change without notice.

### **SAFETY ALERT**

**WARNING:** For safety, purchaser or user should provide protective guards over all shaft extensions and any moving apparatus mounted thereon. The user is responsible for checking all applicable safety codes in his area and providing suitable guards. Failure to do so may result in bodily injury and/or damage to equipment.

**WARNING:** Hot oil or gear units can cause severe burns. Use extreme care when removing lubrication plugs and vents.

**WARNING:** Make certain that the power supply is disconnected before attempting to service or remove any components. Lock out the power supply and tag it to prevent unexpected application of power.

**WARNING:** Any brakes that are used in conjunction with this unit must be sized or positioned in such a way as to not subject the unit to loads beyond the catalog rating.

**CAUTION:** Test run unit to verify operation. If the unit tested is a prototype, that unit must be of current production.

**CAUTION:** If the unit cannot be located in a clear and dry area with access to adequate cooling air supply, then precautions must be taken to avoid the ingestion of contaminants such as water and the reduction in cooling ability due to exterior contaminants. Units located in confined spaces may require forced air-cooling.

## IMPORTANT INFORMATION

In the event of the resale of any of the goods, in whatever form, Resellers/Buyers will include the following language in a conspicuous place and in a conspicuous manner in a written agreement covering such sale:

*The manufacturer makes no warranty or representations, expressed or implied, by operation of law or otherwise, as to the merchantability or fitness for a particular purpose of the good sold hereunder. Buyer acknowledges that it alone has determined that the goods purchased hereunder will suitably meet the requirements of their intended use. In no event will manufacturer be liable for consequential, incidental or other damages.*

Resellers/Buyers agree to also include this entire document including the warnings above in a conspicuous place and in a conspicuous manner in writing to instruct users on the safe usage of the product.

This instruction manual should be read together with all other printed information such as catalogs, supplied by Sterling Electric.

## GENERAL OPERATION

1. Run the motor, which drives the unit, and check the direction of unit output rotation. Consult motor nameplates for instructions to reverse the direction of rotation.
2. Attaching the load: On direct-coupled installations, check shaft and coupling alignment between unit and loading mechanism. On chain/sprocket and belt/pulley installation, locate the sprocket or pulley as close to the oil seal as possible to minimize overhung load. Check to verify that the overhung load does not exceed specifications published in the catalog.
3. High momentum loads: If coasting to a stop is undesirable, a braking mechanism should be provided to the unit output or the driven mechanism.

**CAUTION:** The system of connected rotating parts must be free from critical speed, torsional or other type vibration, no matter how induced. The responsibility for this system analysis lies with the purchaser of the speed reducer.

## INSTALLATION

1. Mount the unit using grade 5 or higher fasteners.
2. For shipment, solid plugs are installed in the unit along with a vent plug with transportation lock which is pre-installed assuming standard horizontal mounting (M1). The vent plug will need to be removed and relocated if the unit is to be mounted in any position other than the standard horizontal position as shown in the chart under **LUBRICATION**. After the unit is mounted, completely remove the transportation lock from the vent plug as directed under **VENT PLUG LOCATION**. Failure to vent the unit can cause premature seal wear or loss of seal and oil. These conditions are not covered by warranty. Check for correct oil level. Contact the factory for level and vent recommendations on non-standard mounting positions.

**CAUTION:** Do not operate the unit without making sure it contains the correct amount of oil. Do not overfill or underfill with oil, or injury to personnel, reducer or other equipment may result.

**CAUTION:** A unit cannot be used as an integral part of a machine superstructure which would impose additional loads on the unit other than those imposed by the torque being transmitted either through a shaft-mounted arrangement, and any shaft mounted power transmitting device. (e.g. sprockets, pulleys, couplings)

**CAUTION:** For safe operation and to maintain the unit warranty, when changing a factory installed fastener for any reason, it becomes the responsibility of the person making the change to properly account for fastener grade, thread engagement, load, tightening torque and the means of torque retention.

### LUBRICATION

**CAUTION:** On **ALL** quill style input units with a motor mounted vertical shaft up or quill under on the input will require a double input seal arrangement to prevent leakage or C-face coupled style units should be used. Consult factory.

All standard helical ratio multipliers ordered from the factory are shipped with standard compounded lubricant and is good for ambient temperature ranges of 30° F to 104° F. All washdown and stainless steel helical ratio multipliers ordered from the factory are shipped with synthetic NSF H1 Food Grade lubricant and are good for ambient temperature ranges of -10° F to 105° F. Double reduction units have separate oil sumps and must be filled and checked independently. Use of synthetics can cause problems if they are not compatible with the seals or conventional lubes they replace. **Prior to startup, verify that the oil is at the level shown on the drawing below.** If the ambient temperature will be outside the range for the lubricant installed at the factory, drain and refill the reducer with the proper viscosity lubricant prior to use.

### VENT PLUG LOCATION

Washdown and stainless steel units are supplied with a Heinrichs Breather with a rubber transportation lock. The transportation lock must be completely removed before operation. Failure to do so may cause the unit to leak. See below.

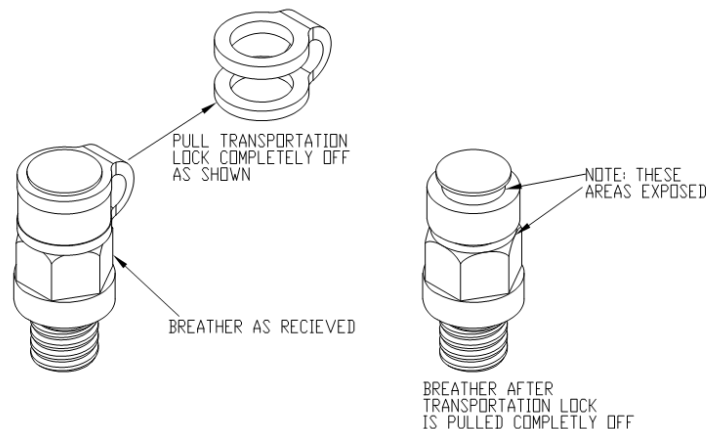

Before putting the unit into operation, it may be necessary to relocate the vent plug for positions other than standard (M1). Substitute the vent plug for the solid plug at the position desired. Install the solid plug in the location the vent plug was removed from. Refer to the following chart for the recommended vent plug locations based on mounting position.

## VENT/ LEVEL/ DRAIN LOCATIONS

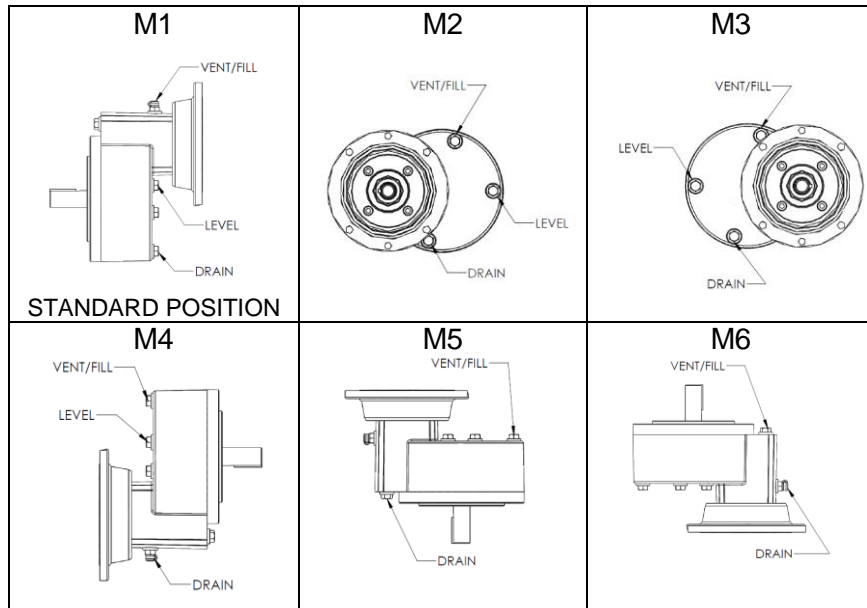

**NOTE:** The unit is filled at the factory with the proper amount of oil for the **STANDARD** mounting position. The level plug is for reference only so the unit can be checked for proper oil level prior to installation and start-up. All other mounting positions will require the oil level to be measured out prior to filling the unit based on the value in the table labeled **OIL CAPACITIES** below.

**CAUTION:** On **ALL** quill style input units, cast iron and stainless with the input mounted vertical shaft up or input under will require a double input seal arrangement to prevent leakage or C-face coupled style units should be used. Consult factory

### OIL & WEIGHT SPECIFICATIONS

RECOMMENDED LUBRICATION OIL (ISO 150)			OIL CAPACITIES (FLUID OUNCE)	
Mineral Oil	PAO† Synthetic	PAO† Synthetic H1 Food Grade	56C/140TC	180TC/210TC
Mobilgear 600XP-150	Mobil SHC 150	Mobil Cibus 150	14	16

†The use of PAG synthetics is not recommended.

**Change Intervals:** Standard compounded lubricants should be changed every six months or 2500 operating hours, whichever comes first. Synthetic lubricants should be changed every two years or 6000 hours, whichever comes first.

**CAUTION:** Oil should be changed more often if the unit is used in a severe environment. (*i.e. dusty, humid*)

**CAUTION:** In the Food and Drug Industry (including animal food), consult the lubrication supplier for recommendation of lubricants which are acceptable to the Food and Drug Administration and/or other authoritative bodies having jurisdiction.

## **MAINTENANCE**

Your Sterling Electric unit has been tested and adjusted at the factory. Dismantling or replacement of components must be done by Sterling Electric to maintain the warranty.

Frequently check the oil level of the unit. If oil level is low, (refer to the vent and level position chart) add proper lubrication through the filler plug until it comes out the oil level plug.

Inspect vent plug often to insure it is clean and operating.

**CAUTION:** Mounting bolts should be routinely checked to ensure that the unit is firmly anchored for proper operation.

## **CLASS OF SERVICE**

All capacity ratings are based on American Gear Manufacturers Association (AGMA) Standards. Load conditions must be within cataloged ratings published in the current Sterling Electric Catalog (available upon request).

## **LONG-TERM STORAGE (6 MONTHS UP)**

Units must be stored indoors, in a dry, warm temperature.

Completely fill the unit with oil.

Rotate the input shaft so that the output shaft rotates at least one revolution per month.

Completely cover the input and output shaft with grease.

At the time of start up, drain the storage oil, install the breather, and fill to the proper oil level with correct lubricant for the operating condition.

## **WARRANTY (LIMITED)**

The warranty will cover all of the parts in the gearmotor or reducer unit for 12 months from the date of shipment.

The warranty is only for parts and labor. In no event shall our liability exceed the original price of the unit, nor does it cover cost of on site repair, installation, or freight.

Contact the service department for a complete explanation as to the full warranty policies and conditions of sale.

**All dimensions designs and specifications are subject to change without notice**

## SEAL AND BEARING SIZES

### Input Bearing

Motor Input	Bearing Part Number and Size				
	Series	OD (mm)	ID (mm)	Width (mm)	Sterling P/N
56C/140TC	6206	62	30	16	400-0008-9
180TC/210TC	6206	62	30	16	400-0008-9

### ODE Output Bearing

Motor Output	Bearing Part Number and Size				
	Series	OD (mm)	ID (mm)	Width (mm)	Sterling P/N
56C/140TC	6305	62	25	17	400-0495-5
180TC/210TC	6305	62	25	17	400-0495-5

### DE Output Bearings

Motor Input	Bearing Part Number and Size				
	Series	OD (mm)	ID (mm)	Width (mm)	Sterling P/N
56C/140TC	6206	62	30	16	400-0008-9
180TC/210TC	6207	72	35	17	400-0009-7

### Input Seal

Motor Input	Bearing Part Number and Size			
	Shaft (mm)	Bore (mm)	Width (mm)	Sterling P/N
56C/140TC (Item #4)	35	50	8	404-0292-8
56C/140TC (Item #15)*	35	62	7	404-0350-0
180TC/210TC (Item #21)	50	60	8	404-0377-3
180TC/210TC (Item #24)*	50	62	7	404-0452-8

\*Only present on units with double input seal option.

### Output Seal

Motor Output	Bearing Part Number and Size			
	Shaft (mm)	Bore (mm)	Width (mm)	Sterling P/N
56C/140TC	30	50	7	404-0291-9
180TC/210TC	35	55	8	404-0294-6

## 56C/140TC PARTS

Item No.	Description	Qty	Item No.	Description	Qty
1	INPUT QUILL SHAFT	1	13	HEINRICHS BREATHER	1
2	BALL BEARING	2	14	SEAL PLUG	4
3	EXTERNAL SNAP RING	1	15	METRIC SEAL	1
4	METRIC SEAL	1	16	SPACER RING/ SPLASH GUARD	1
5	METRIC SEAL	1	17	SOLID OUTPUT GEAR	1
6	BALL BEARING	1	18	PINION	1
7	SOCKET HEAD CAP SCREW	10	19	SPACER	1
8	O-RING	1	20	SS2RBQ ONE PIECE HOUSING	1
9	METRIC KEY	1	21	C-FACE OUTPUT CAP	1
10	SLINGER	1	22	OUTPUT SHAFT	1
11	KEY	1	23*	O-RING	1
12	INTERNAL SNAP RING	1	24	INPUT FLANGE	1

\*Applies to Stainless Steel units only.

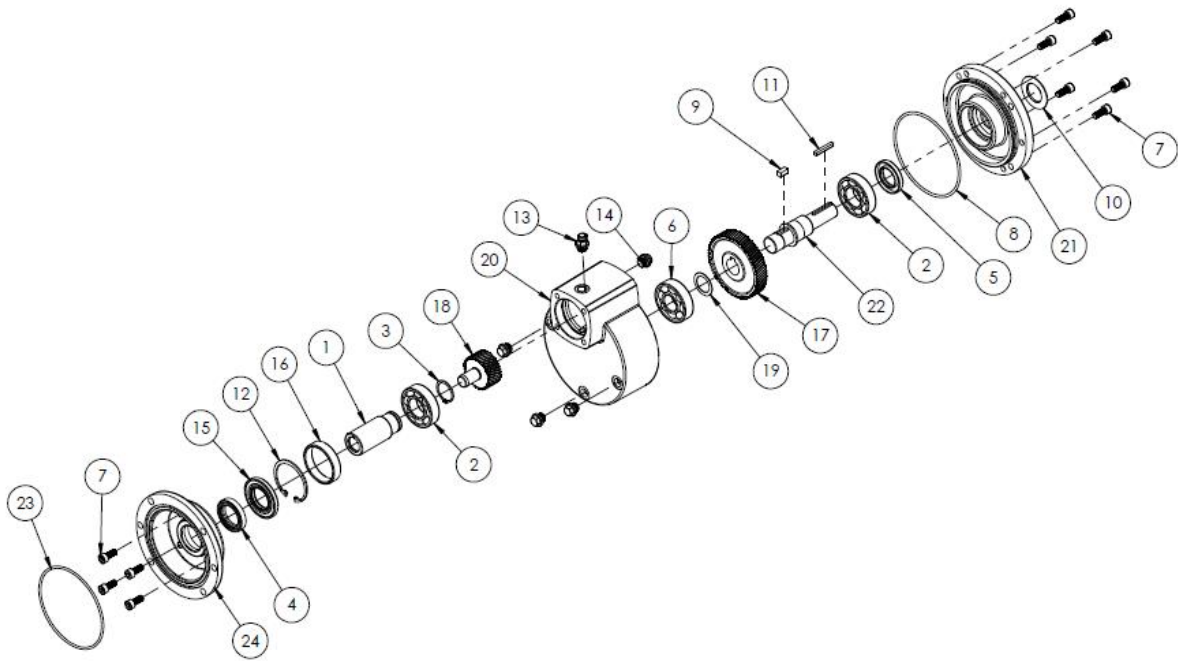



## 180TC/210TC PARTS

Item No.	Description	Qty	Item No.	Description	Qty
1	ONE PIECE HOUSING	1	14	C-FACE OUTPUT CAP	1
2	BALL BEARING	1	15	SOCKET HEAD CAP SCREW	6
3	EXTERNAL SNAP RING	1	16	OUTPUT SHAFT	1
4	BALL BEARING	1	17	BALL BEARING	1
5	SPACER	1	18	METRIC SEAL	1
6	O-RING	1	19	KEY	1
7	METRIC KEY	1	20	INPUT FLANGE	1
8	INTERNAL SNAP RING	1	21	INPUT QUILL SHAFT	1
9	HEINRICHS BREATHER	1	22	METRIC SEAL	1
10	SEAL PLUG	4	23	SOCKET HEAD CAP SCREW	4
11	PINION	1	24	V-SEAL	1
12	OUTPUT GEAR	1	25	METRIC SEAL	1
13	SPACER RING/ SPLASH GUARD	1	26*	O-RING	1

\*Applies to Stainless Steel units only.

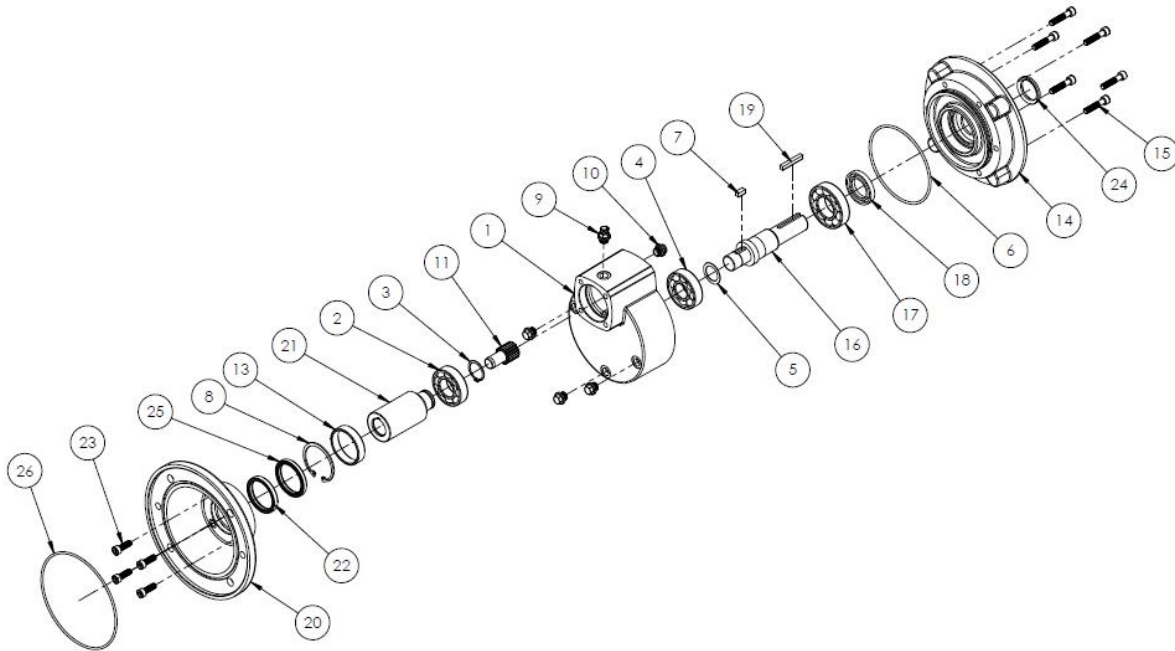

**Indianapolis, Indiana (800) 866-7973**

**e-mail: [sales@sterlingelectric.com](mailto:sales@sterlingelectric.com)  
[www.sterlingelectric.com](http://www.sterlingelectric.com)**