

Motor Mounting Dimensions

FRAME	E	F	H	BA	A	B	C	D	G	J	O	P	R	S	T	AA	AB	AC	N-W	U	D.E. BRG	O.D.E. BRG
254T	5.0	4.125	0.53	4.25	12.2	10.1	23.5	6.25	0.83	2.56	13.0	13.5	1.416	.375	2.4	1-1/4	11.0	8.6	4.00	1.625	6309	6309
256T	5.0	5.00	0.53	4.25	12.2	12.8	25.2	6.25	0.83	2.56	13.0	13.5	1.416	.375	2.4	1-1/4	11.0	8.6	4.00	1.625	6309	6309
284T	5.5	4.75	0.53	4.75	13.8	12.3	26.6	7.0	0.94	2.76	14.6	15	1.591	.500	2.4	1-1/2	13.4	10.0	4.62	1.875	6311	6311
284TS	5.5	4.75	0.53	4.75	13.8	12.3	25.2	7.0	0.94	2.76	14.6	15	1.416	.375	2.4	1-1/2	13.4	10.0	3.25	1.625	6311	6311
286T	5.5	5.50	0.53	4.75	13.8	13.8	28.1	7.0	0.94	2.76	14.6	15	1.591	.500	2.4	1-1/2	13.4	10.0	4.62	1.875	6311	6311
286TS	5.5	5.50	0.53	4.75	13.8	13.8	26.7	7.0	0.94	2.76	14.6	15	1.416	.375	2.4	1-1/2	13.4	10.0	3.25	1.625	6311	6311
324T	6.25	5.25	0.66	5.25	15.4	14.8	31.7	8.0	0.98	2.76	15.8	16.7	1.845	.500	2.5	2	15.0	10.9	5.25	2.125	6312	6312
324TS	6.25	5.25	0.66	5.25	15.4	14.8	30.2	8.0	0.98	2.76	15.8	16.7	1.591	.500	2.5	2	15.0	10.9	3.75	1.875	6312	6312
326T	6.25	6.00	0.66	5.25	15.4	16.3	33.3	8.0	0.98	2.76	15.8	16.7	1.845	.500	2.5	2	15.0	10.9	5.25	2.125	6312	6312
326TS	6.25	6.00	0.66	5.25	15.4	16.3	31.7	8.0	0.98	2.76	15.8	16.7	1.591	.500	2.5	2	15.0	10.9	3.75	1.875	6312	6312
364T	7.0	5.625	0.66	5.88	17.1	15.0	33.7	9.0	0.94	3.11	17.8	18.1	2.021	.625	2.5	3	17.5	12.9	5.88	2.375	6314	6314
364TS	7.0	5.625	0.66	5.88	17.1	15.0	31.5	9.0	0.94	3.11	17.8	18.1	1.591	.500	2.5	3	17.5	12.9	3.75	1.875	6314	6314
365T	7.0	6.125	0.66	5.88	17.1	17.4	37.1	9.0	0.94	3.11	17.8	18.1	2.021	.625	2.5	3	17.5	12.9	5.88	2.375	6314	6314
365TS	7.0	6.125	0.66	5.88	17.1	16.2	34.9	9.0	0.94	3.11	17.8	18.1	1.591	.500	2.5	3	17.5	12.9	3.75	1.875	6314	6314

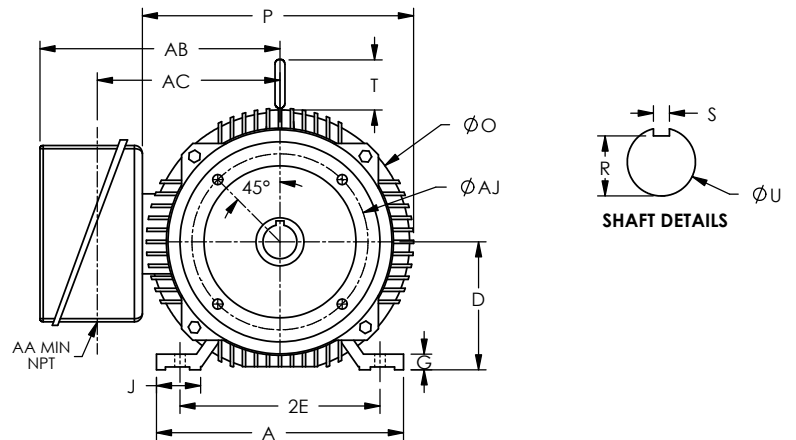
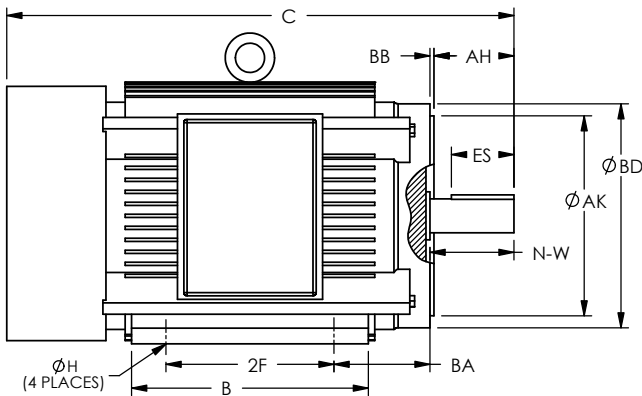

Motor C-Face Mounting Dimensions

FRAME	AJ	AK	BA	BB MIN	BD MAX	# OF TAPS	THREAD	DEPTH OF TAP	U	AH	R	ES	S
254TC.256TC	7.25	8.50	4.25	.25	9.00	4	1/2-13	0.75	1.625	3.75	1.416	2.91	0.375
284TC.286TC	9.00	10.50	4.75	.25	11.25	4	1/2-13	0.75	1.875	4.38	1.591	3.28	0.500
284TSC.286TSC	9.00	10.50	4.75	.25	11.25	4	1/2-13	0.75	1.625	3.00	1.416	1.91	0.375
324TC.326TC	11.00	12.50	5.25	.25	14.00	4	5/8-11	0.94	2.125	5.00	1.845	3.91	0.500
324TSC.326TSC	11.00	12.50	5.25	.25	14.00	4	5/8-11	0.94	1.875	3.50	1.591	2.03	0.500
364TC.365TC	11.00	12.50	5.88	.25	14.00	8	5/8-11	0.94	2.375	5.62	2.021	4.28	0.625
364TSC.365TSC	11.00	12.50	5.88	.25	14.00	8	5/8-11	0.94	1.875	3.50	1.591	2.03	0.500