

STERLING ELECTRIC, INC.

DRIP-PROOF TYPE
SQUIRREL CAGE ROTOR
FOOT MOUNTED
(EXTRA MAX)

PROJECT NO:

CUSTOMER:

PO. NO:

ORDER NO:

OUTPUT	POLE	SYN. SPEED RPM.	VOLT. V.	FREQ HZ	INSUL. F	TIME RATING CONT.	MODEL ODP	FRAME NO. 365T
--------	------	--------------------	-------------	------------	-------------	----------------------	--------------	-------------------

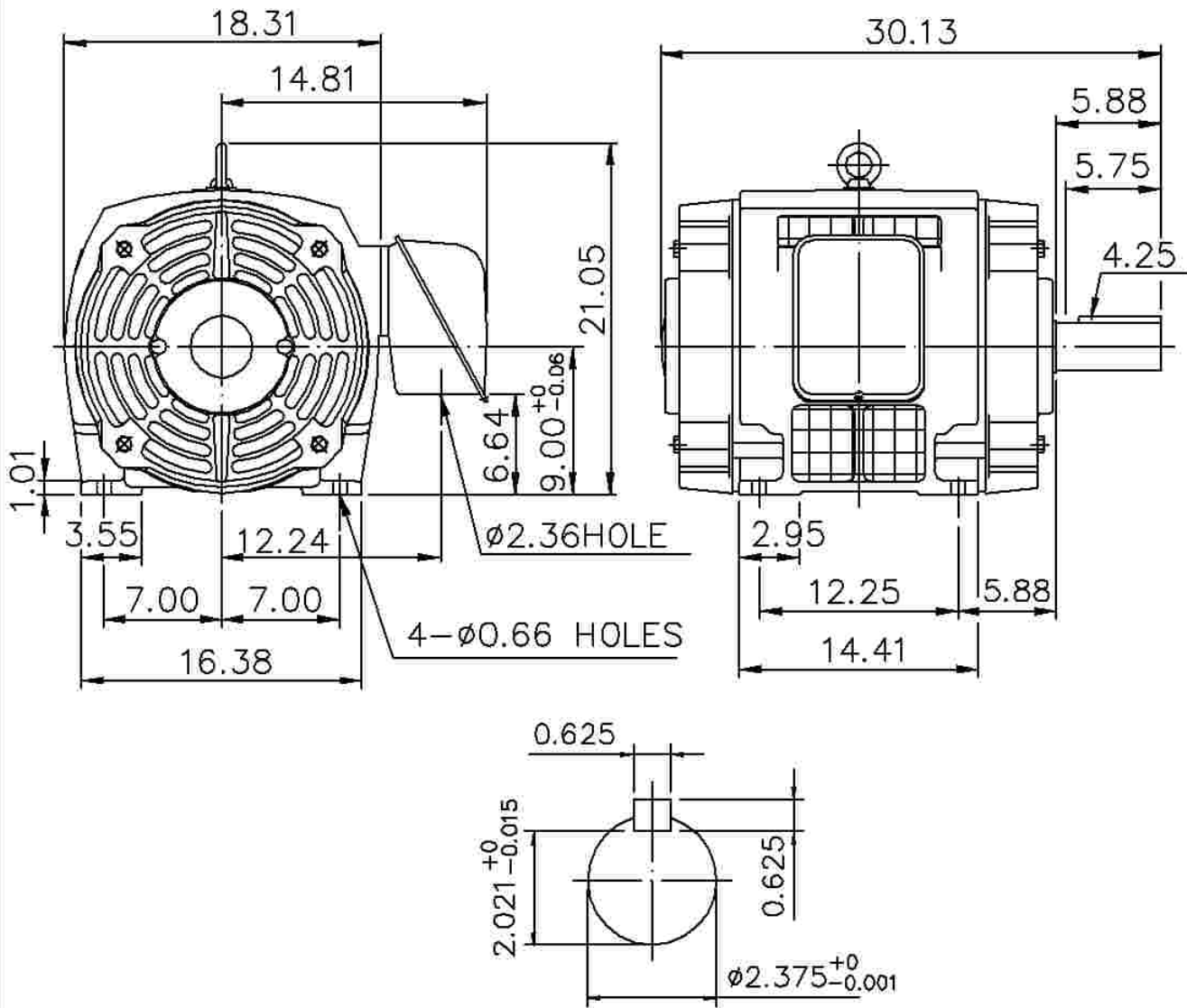

NOTE: 1. APPROXIMATE WEIGHT = 830 LBS
2. DRIVE END BEARING 6314
OPPOSITE DRIVE END BEARING 6313

STERLING ELECTRIC, INC.

DESIGNED

CHECKED

APPROVED

DIMENSIONS IN INCHES

3RD ANGLE PROJECTION

DATE: