

OUTLINE 3-PHASE INDUCTION MOTOR

TOTALLY ENCLOSED FAN
COOLED, SQUIRREL CAGE
ROTOR

E-MOTOR

FILE NO:

CUSTOMER:

PO. NO:

ORDER NO:

OUTPUT	POLE	SYN. SPEED	VOLT.	FREQ	TIME RATING	MODEL	FRAME NO.
					CONT.	TEFC	326TC

MOTOR CODE :

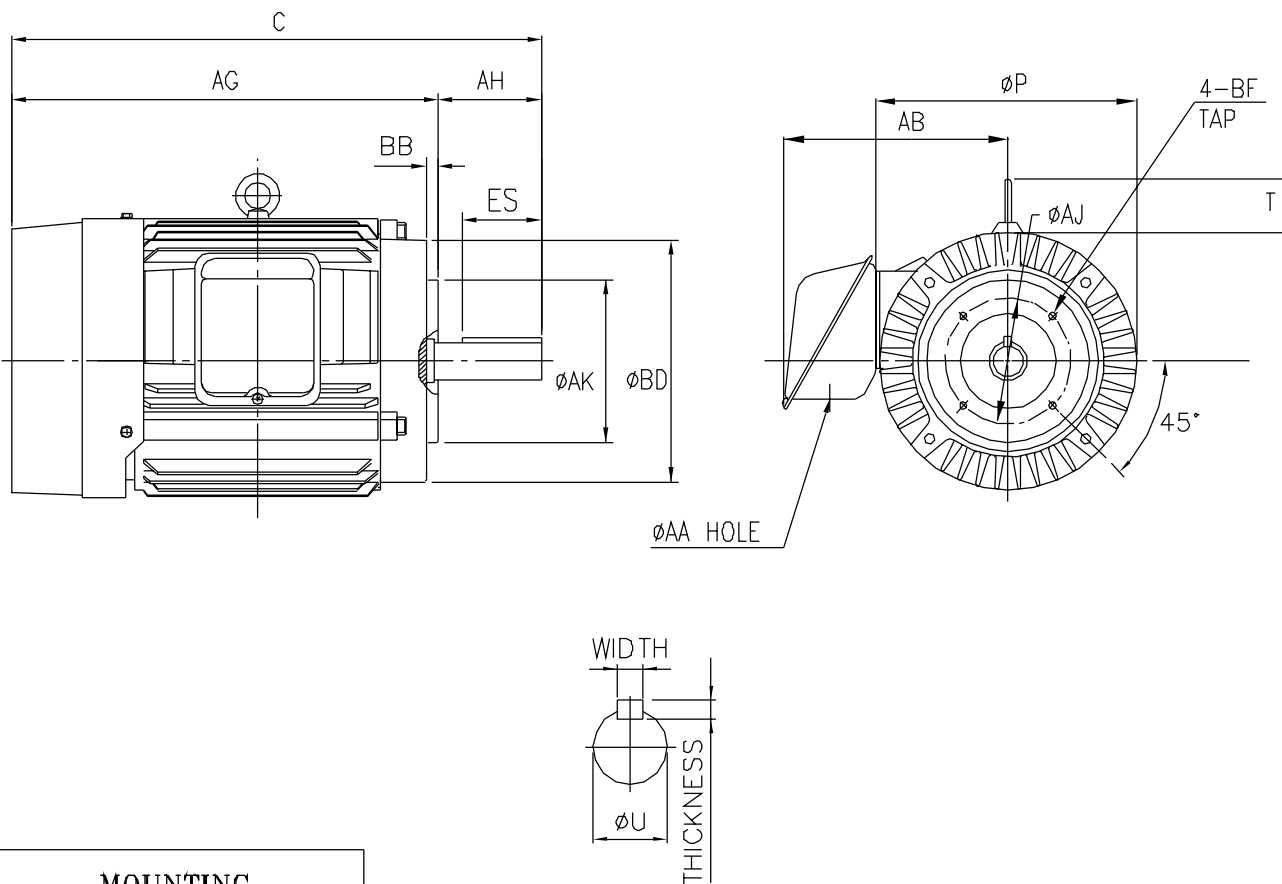

MOUNTING				E	2F	H	BA	A	B	C	D	G	J	P	AA	AB	AG	AJ
										31.82				17.75	2.36	14.37	26.32	11.00

C-FACE			T	BB	KEY			SHAFT EXT.		BEARING NO.		APPROX WEIGHT
AK	BD	BF			WIDTH	THICKNESS	ES	AH	U	D.E	O.D.E	
12.50	14.00	.63-11	2.36	.25	0.50	0.50	2.03	5.00	2.125	6312	6312	

- NOTE: 1. TOLERANCE OF SHAFT END DIAMETER U: +0.000, -0.001
 2. TOLERANCE OF SHAFT CENTER HEIGHT D: +0.001, -0.03
 3. DIMENSION AH IS LENGTH OF STRAIGHT PART OF SHAFT.
 4. CLASS INSULATION.

STERLING
ELECTRIC, INC.
 IRVINE CA.

DESIGNED		DIMENSION IN INCHES
CHECKED		3RD ANGLE PROJECTION
APPROVED		DWG. NO: 326TC