

STERLING ELECTRIC, INC.

IRVINE, CA

TOTALLY ENCLOSED FAN
COOLED, SQUIRREL CAGE
ROTOR (E SERIES)

FILE NO:
CUSTOMER:
P.O. NO:
ORDER NO:

OUTPUT	POLE	SYN. SPEED	VOLT.	FREQ	TIME RATING	MODEL	FRAME NO.
					CONT.	TEFC	286TC

MOTOR CODE :

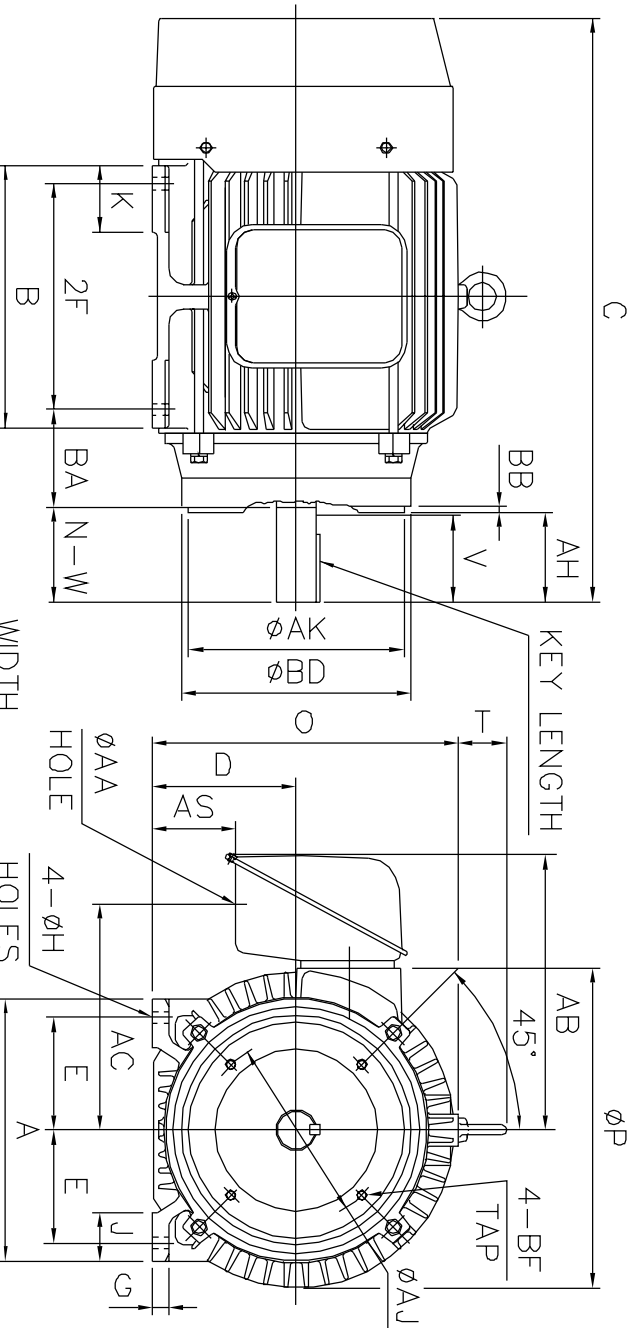

FLANGE				
AJ	AK	BB	BD	BF
9.00	10.50	0.25	11.25	1/2-13

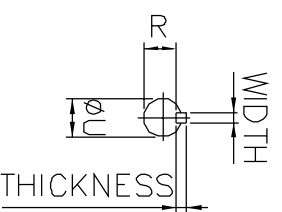

A	B	C	D	E	2F	G	H	J	K	O+T	P	AA	AB	AH
12.76	12.76	28.4	7.00	5.50	11.0	0.79	0.53	2.36	3.25	17.30	15.67	2.36	13.4	4.38

AC	AS	BA	KEY		KEYSEAT	SHAFT EXTENSION		BEARING NO.		APPROX WEIGHT (LBS)		
			WIDTH	THICK- NESS		R	N-W	U	V		D.E	O.D.E
11.0	4.13	4.75	0.50	0.50	3.25	1.591	4.62	1.875	4.5	6310ZZ	6210ZZ	513

- NOTE:1. TOLERANCE OF SHAFT END DIAMETER U: +0.000, -0.001
 2. TOLERANCE OF SHAFT CENTER HEIGHT D: +0.000, -0.03
 3. DIMENSION R TOLERANCE: +0.000, -0.015
 4. DIMENSION AK TOLERANCE: +0.000, -0.003
 5. DIMENSION V IS LENGTH OF STRAIGHT PART OF SHAFT.
 6. F CLASS INSULATION.

SCALE 1:9

DESIGNED	DIMENSION IN INCHES
CHECKED	3RD ANGLE PROJECTION
APPROVED	DWG. NO: 286TC