

OUTPUT	POLE	SYN. SPEED	VOLT.	FREQ	TIME RATING	MODEL	FRAME NO.
					CONT.	TEFC	284TC

MOTOR CODE :

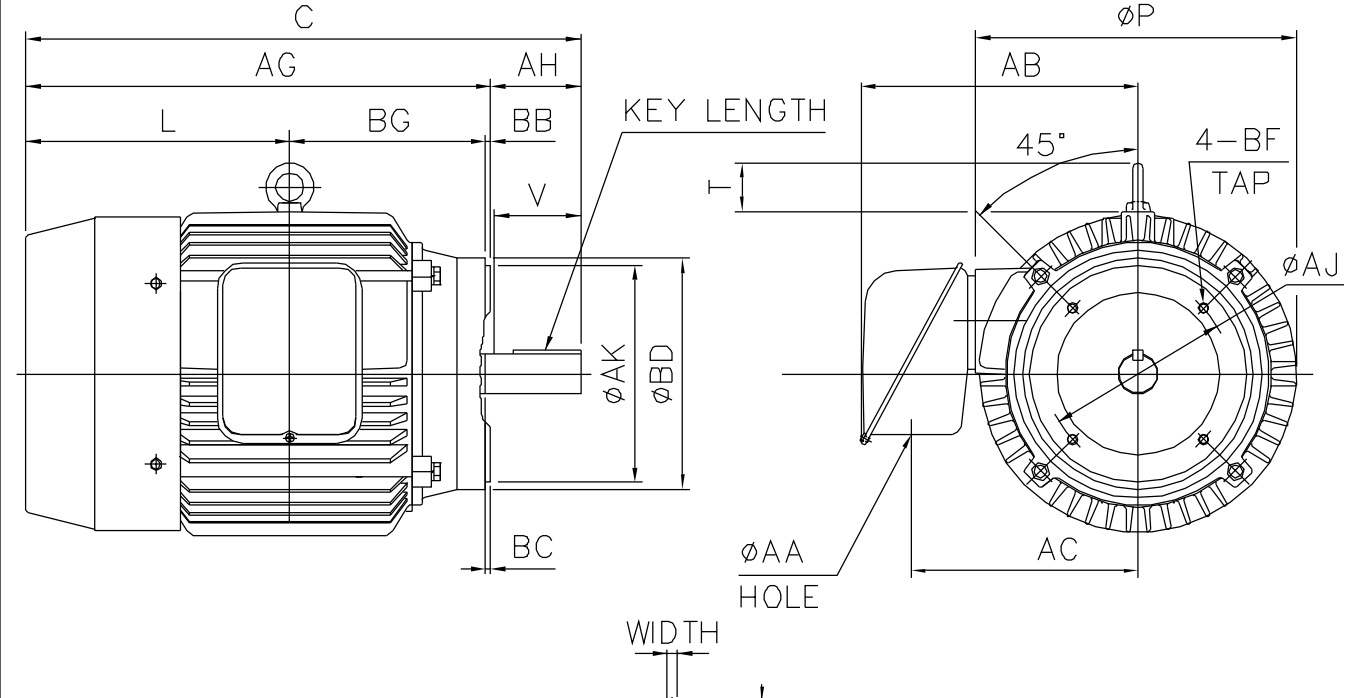

FLANGE				
AJ	AK	BB	BD	BF
9.00	10.50	0.25	11.25	1/2-13

-	-	C	-	-	-	-	-	L	P	T	AA	AB	AC	AH
-	-	26.9	-	-	-	-	-	17.9	15.67	2.36	2.36	13.4	11.0	4.38

AG	BC	BG	KEY			KEYSEAT R	SHAFT EXTENSION			BEARING NO.		APPROX WEIGHT (LBS)
			WIDTH	THICKNESS	LENGTH		-	U	V	D.E	O.D.E	
27.6	0.25	9.50	0.50	0.50	3.25	1.591	-	1.875	4.5	6310ZZ	6210ZZ	390

- NOTE: 1. TOLERANCE OF SHAFT END DIAMETER U: +0.000, -0.001
 2. DIMENSION R TOLERANCE: +0.000, -0.015
 3. DIMENSION AK TOLERANCE: +0.000, -0.003
 4. DIMENSION V IS LENGTH OF STRAIGHT PART OF SHAFT.
 5. F CLASS INSULATION.

		SCALE 1:9
DESIGNED		DIMENSION IN INCHES
CHECKED		3RD ANGLE PROJECTION
APPROVED		DWG. NO: 284TC