

STERLING ELECTRIC, INC.

IRVINE, CA

TOTALLY ENCLOSED FAN
COOLED, SQUIRREL CAGE
ROTOR (E SERIES)

FILE NO:

CUSTOMER:

PO. NO:

ORDER NO:

| OUTPUT | POLE | SYN. SPEED | VOLT. | FREQ | TIME RATING | MODEL | FRAME NO. |
|--------|------|------------|-------|------|-------------|-------|-----------|
| | | | | | CONT. | TEFC | 254TC |

MOTOR CODE :

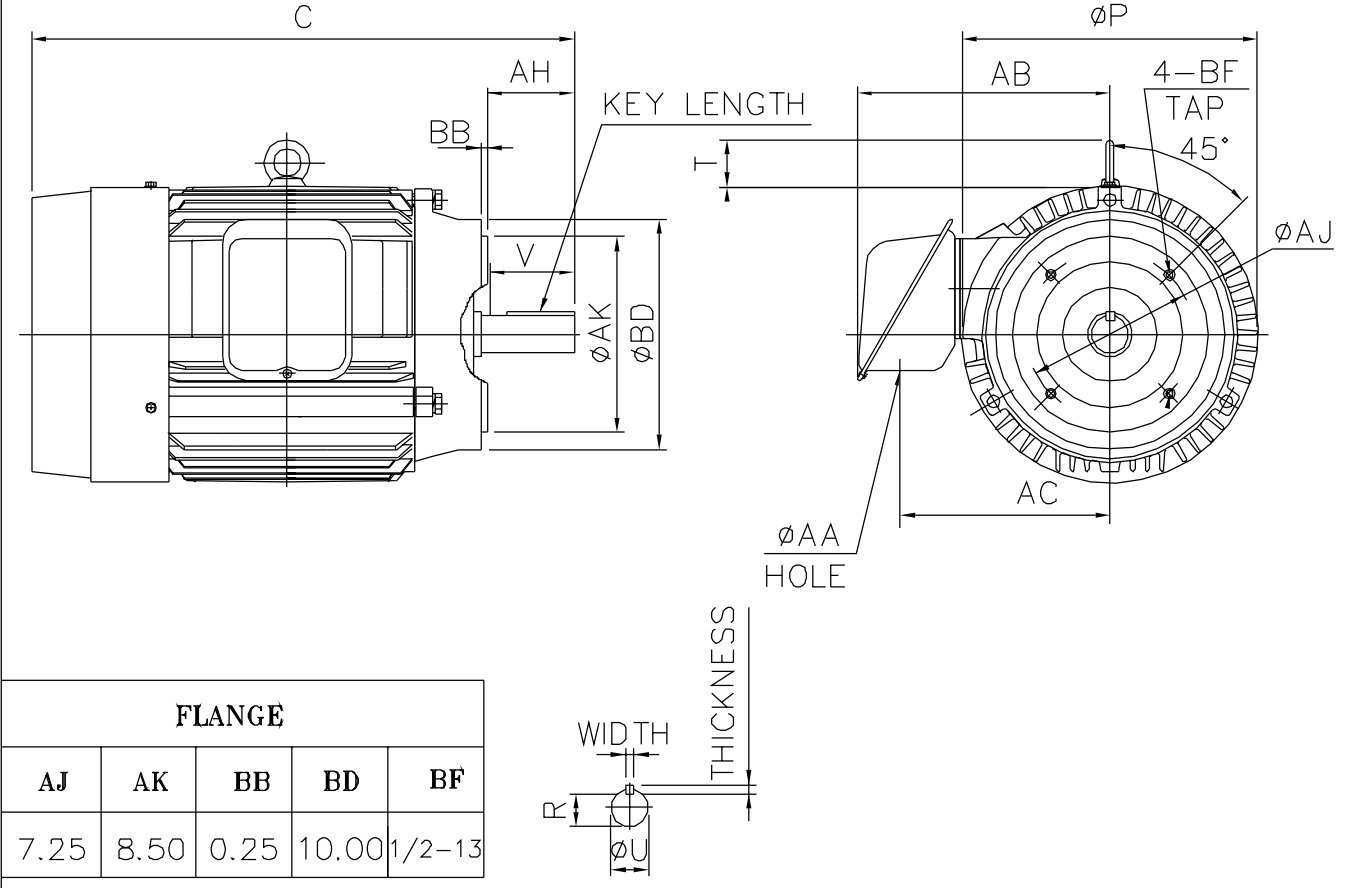

FLANGE

| AJ | AK | BB | BD | BF |
|------|------|------|-------|--------|
| 7.25 | 8.50 | 0.25 | 10.00 | 1/2-13 |

| A | B | C | D | E | 2F | G | H | J | T | P | AA | AB | AH |
|---|---|-------|---|---|----|---|---|---|-----|-------|------|-------|------|
| - | - | 23.40 | - | - | - | - | - | - | 2.0 | 12.80 | 2.05 | 10.80 | 3.75 |

| AC | AS | BA | KEY | | | KEYSEAT | SHAFT EXTENSION | | | BEARING NO. | | APPROX WEIGHT (LBS) |
|------|----|----|-------|-----------|--------|---------|-----------------|-------|------|-------------|--------|---------------------|
| | | | WIDTH | THICKNESS | LENGTH | R | N-W | U | V | D.E | O.D.E | |
| 8.82 | - | - | 0.375 | 0.375 | 2.875 | 1.416 | - | 1.625 | 3.90 | 6310ZZ | 6208ZZ | 253 |

- NOTE: 1. TOLERANCE OF SHAFT END DIAMETER U: +0.000, -0.001
 2. TOLERANCE OF SHAFT CENTER HEIGHT D: +0.000, -0.03
 3. DIMENSION R TOLERANCE: +0.000, -0.015
 4. DIMENSION AK TOLERANCE: +0.000, -0.003
 5. DIMENSION V IS LENGTH OF STRAIGHT PART OF SHAFT.
 6. CLASS INSULATION.

SCALE 1:8

| | | |
|----------|--|----------------------|
| DESIGNED | | DIMENSION IN INCHES |
| CHECKED | | 3RD ANGLE PROJECTION |
| APPROVED | | DWG. NO: 254TC |