

# STERLING ELECTRIC, INC.

DRIP-PROOF TYPE  
SQUIRREL CAGE ROTOR  
FOOT MOUNTED  
(EXTRA MAX)

PROJECT NO:

CUSTOMER:

PO. NO:

ORDER NO:

OUTPUT	POLE	SYN. SPEED RPM.	VOLT. V.	FREQ HZ	INSUL. F	TIME RATING CONT.	MODEL ODP	FRAME NO. 21ST
--------	------	--------------------	-------------	------------	-------------	----------------------	--------------	-------------------

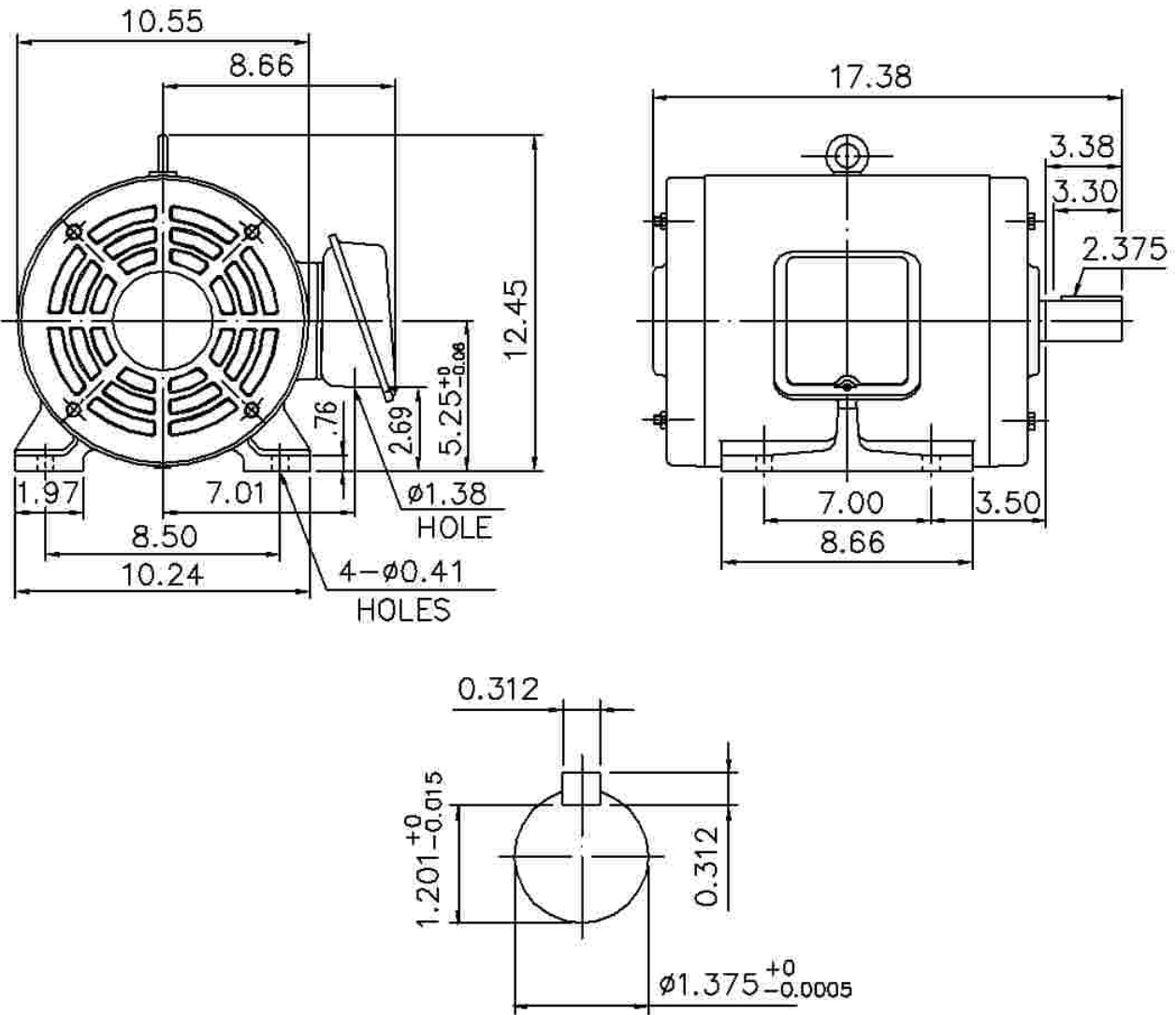

NOTE: 1. APPROXIMATE WEIGHT = 157 LBS  
2. DRIVE END BEARING 6308zz  
OPPOSITE DRIVE END BEARING 6208zz

# STERLING ELECTRIC, INC.

DESIGNED		DIMENSIONS IN INCHES
CHECKED		3RD ANGLE PROJECTION
APPROVED		DATE: